

FIRETRACE
AUTOMATIC FIRE SUPPRESSION SYSTEMS

Fire Protection for Manufacturing Facilities

“Micro Environment” Protection

September 2009



Details on fires in manufacturing facilities and how to suppress them using **FIRETRACE**® automatic suppression systems

Background Information

With the demands from the world for faster more efficient manufacturing facilities the possibility of a fire becomes an ever growing risk. Statistics show 40% of businesses that experience fires never recover so finding a fast and suitable protection is more important than ever.



As there are so many workshops running 24 hours a day, relying on ground staff is often not practice and by the time a fire has been detected the entire machine or even workshop may have been lost. **FIRETRACE®** overcomes this problem by detecting the fire inside the machine and directly at its source, this allows for early detection and subsequently minimal damage and downtime.

FIRETRACE® Systems have been installed on thousands of Manufacturing facilities around the world, protecting not only CNC and cutting equipment, but also presses, EDM machines, dust extractors and filters, electrical control panels and other similar high-risk areas.

Following a fire in Forest Park, USA at a manufacturing facility which did not require smoke alarms or sprinkler systems as it was considered low risk, 140 fire-fighters were required to tackle the blaze and resulted in costing the facility 10 million dollars in damage.

FIRETRACE® systems require no power to run; they are fully automatic, and easy to maintenance. All this adds up to **FIRETRACE®** systems suppressing 4 fires every week throughout the USA.

The recently updated EU Machinery Directive 2006-42-EC states, machinery comprising of highly flammable parts must be fitted with built in extinguishing systems.

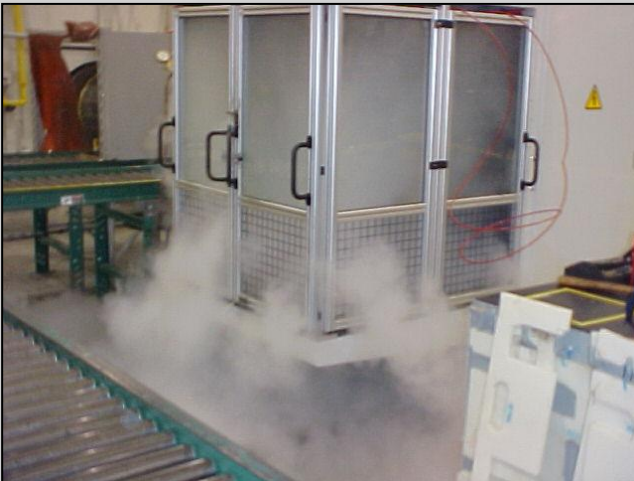

FIRETRACE® has been installed in thousands of CNC Machines all around the world using our patented Firetrace Detection Tubing.

Systems require no external power to operate, and very little maintenance

System only activates in the event of a fire, no false alarms due to smoke or vibration

FIRETRACE® systems extinguish around 4 fires every week in the USA

Easy to retrofit old machinery and new builds

Targeted detection around cutting equipment and high risk areas to ensure a quick detection



Protect the whole facility from the machines to the extractors

Quick acting so only minimal damage is done to equipment

System can be quickly replaced after a fire has taken place

FIRETRACE® in Action

On this \$300,000 grinding machine there was not enough cooling fluid being dispensed behind the grinding wheel, this created a highly ignitable mist. The mist was quickly and violently ignited by a spark, and a flash fire occurred inside the chamber. The detection tubing detected the fire in front of the mist collection unit and instantly dispensed the FM-200 through the two Discharge Nozzles. The fire was extinguished immediately. The operator actually hit the manual release, but he later realized the system had already activated before he hit it.



Swiss type turning machines are designed to be safe and prevent conditions that can lead to a fire; however they can still have problems when not properly operated. In the machine pictured here the machine was excessively hot due to improper operation and caused the cooling oil to ignite, this created a substantial fire very quickly. Luckily this machine had a FIRETRACE® system installed and the tube detected the fire in a matter of seconds and extinguished it. Following this instance the owners went on to install FIRETRACE® on all 24 of their other machines.

How **FIRETRACE**® works

FIRETRACE® employs a flexible detection and delivery system called Firetrace Tubing. The tubing is manufactured from specially processed polymer materials to achieve the desired heat detection and delivery characteristics.

The **FIRETRACE**® Tubing, which is pressurized, is placed within an enclosed area above potential fire hazards and secured in place with brackets provided. Extinguishing mediums can be matched to the particular application. Various system sizes are available to accommodate the appropriate amount of agent. The systems require no power to run and require minimum maintenance.



The Direct **FIRETRACE**® system discharges the suppression agent directly from the burst hole in the tube, this will be the closest point to the fire, and will allow the fastest extinguishing time and minimum spread of the fire.

The Indirect **FIRETRACE**® system discharges the suppression agent into the protected area via plumbed diffusers that are initiated by the Firetrace tube bursting, this allows agent to be delivered quickly and directed at a specific point.



Common applications

FIRETRACE® systems are used to protect:

- CNC Machines
- EDM Machines
- Turning machines and Lathes
- Presses
- Grinders
- Electrical control cabinets
- Air filters
- Dust extractors



Units can be easily retrofitted around existing machinery and can be fitted and replaced in a matter of hours.

Firetrace systems can utilise both high and low pressure systems depending on the hazard type and location

This system uses 6lb's of FM-200 to completely flood the inside of this machine.

FIRETRACE® will work to design a system specifically for the equipment critical to you and your business.



Agents

The **FIRETRACE**® fire detection system can be offered as either a direct or indirect system, with localised suppression and total envelopment of the fire with a range of agents, including but not limited to:-

- Novec 1230
- FM-200 (HFC227ea)
- CO₂
- Dry Powders (multi-purpose and class D)
- Foam

Novec 1230 Fire protection fluid

The extinguishing agent used in **FIRETRACE**® pre-engineered automatic indirect fire suppression units is Dodecafluoro-2-methylpentan-3-one, more commonly known as Novec 1230.

Novec 1230 is a colourless low odour fluid, low in toxicity, electrically non-conductive, leaves no residue, and is an extremely effective fire suppression agent. Novec 1230 is included in NFPA-2001, under the generic name FK-5-1-12, and has been evaluated and approved for use in occupied areas as a Total Flooding agent; when used as specified under the U.S. Environmental Protection Agency (EPA) SNAP Program rules.



Cleanliness

Novec 1230 is clean and leaves no residue, thereby minimizing after fire clean up along with keeping expensive downtime to a minimum. Most materials such as steel, aluminium, stainless steel, brass, as well as plastics, rubber and electronic components are not affected by exposure to Novec 1230. This agent is also environmentally friendly, having ozone depletion potential (ODP) of 0.00 and an atmospheric lifetime of 5 days (the closest halocarbon alternative is 33 years). (3M, 2003)

(3M, 2003)

3M™ Novec™ 1230 Fire Protection Fluid Environmental Properties Comparison

Properties	Novec 1230	Halon 1211	Halon 1301	HFC-125	HFC-227ea	HFC-23
Ozone Depletion Potential (ODP) ¹	0.0	5.1	12.0	0.0	0.0	0.0
Global Warming Potential-IPCC ²	1	1300	6900	3400	3500	12000
Atmospheric Lifetime (years)	0.014	11	65	29	33	260
SNAP (Yes/No)	Yes	N/A	N/A	Yes	Yes	Yes

¹ World Meteorological Organization (WMO) 1998, Model-Derived Method

² Intergovernmental Panel on Climate Change (IPCC) 2001 Method, 100 Year ITH

HFC-227ea Extinguishing Agent

An alternative extinguishing agent used in **FIRETRACE**[®] pre-engineered automatic direct fire suppression units for electrical enclosures is Heptafluoropropane, more commonly known as HFC-227ea, or FM200. HFC-227ea is a colourless odourless gas, low in toxicity, electrically non-conductive, leaves no residue, and is an extremely effective fire suppression agent.

HFC227ea has been the standard clean agent for many years and is well know and trusted worldwide for its effectiveness and quality.

HFC-227ea is included in NFPA-2001 and has been evaluated and approved for use in occupied areas as a Total Flooding agent.

HFC-227ea is clean and leaves no residue, thereby minimizing after fire clean up along with keeping expensive downtime to a minimum. Most materials such as steel, aluminium, stainless steel, brass, as well as plastics, rubber, and electronic components are not affected by exposure to HFC-227ea. This agent is also environmentally friendly, having an ozone depletion potential (ODP) of 0.00.

For hazard information, decomposition information, and physical properties of FM200 please refer to the Material Safety Data sheet located in the System Manual, or contact Firetrace International Ltd.

Dry Chemical Extinguishing Agents

The dry chemical extinguishing agent used in the **FIRETRACE**[®] dry chemical pre-engineered automatic fire suppression units shall be Mono Ammonium Phosphate ($\text{NH}_4\text{H}_2\text{PO}_4$) also known as ABC or multi-purpose powder. ABC powder is one of the most common agents used in hand held fire extinguishers and is a particularly effective fire suppression agent pound for pound.

ABC Powder is included in NFPA-17 and has been evaluated and approved for use in occupied areas, provided the proper safety precautions have been taken.

Dry Chemical is a finely divided powder that has been treated to be water repellent and capable of being fluidized and free flowing so that it can be discharged through hoses and piping under the influence of an expellant gas. When discharged, dry chemical will drift through the air and settle on surrounding surfaces.

System Choice for CNC machine

The **FIRETRACE**® Systems used on CNC and Grinding machines typically consist of a small, pressurized container using clean agent as the extinguishing medium. This is connected to a length of Firetrace Detection Tube (FDT) that is appropriately routed around the cutting area to provide linear, pneumatic detection in a 360 degree environment. Nozzles will be placed in strategic locations around the hazard area to extinguish the fire as quickly as possible.

In the event of a fire, or high temperature rise, the FDT will burst and activate the valve, now the agent is released through the discharge pipes and onto the fire. The agent quickly fills the machine and extinguishes the fire, it leaves no residue and is electrically non conductive so will not cause and damage to the equipment.

The system is also fitted with a pressure switch that constantly monitors the contents of the container and can be used to sound an alarm or be integrated into an existing fire alarm panel. It can also be used to shut powder down to the machine ensuring that the original fault (lack of lubricant etc...) will not cause the fire to re-ignite

Firetrace Detection Tubing is ideal for fire detection in CNC machines as it tolerates the vibration, dirt, temperature extremes of the environments in which the machines operate. Also, being pneumatically operated they require no power to run and do not rely on any electronic sensor equipment, this means we only discharge the system if there is a fire, no false alarms.

Swiss-Type Turning Machines

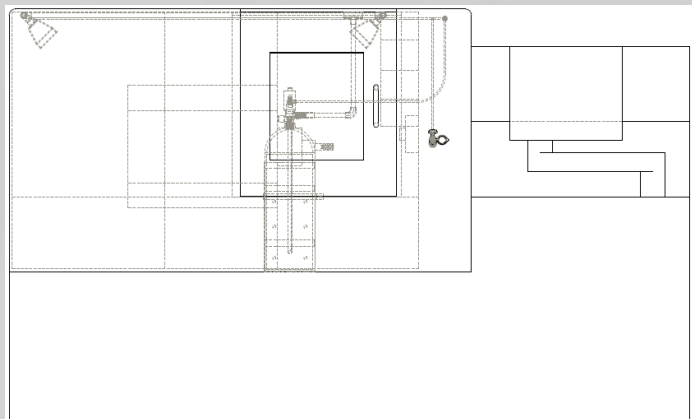
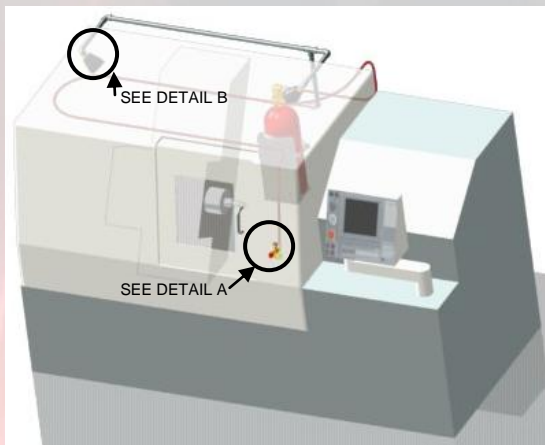

System specifications

Cylinder and Mounting Bracket

FIRETRACE® systems can utilise both TPED and D.O.T cylinders made from either aluminium or steel. Each cylinder is finished in red and painted to resist corrosion.

A wall mounted painted steel bracket is used to mount the cylinder/valve assembly in a vertical (upright) position. Each bracket is equipped with integral quick-clamp straps and locking pin.

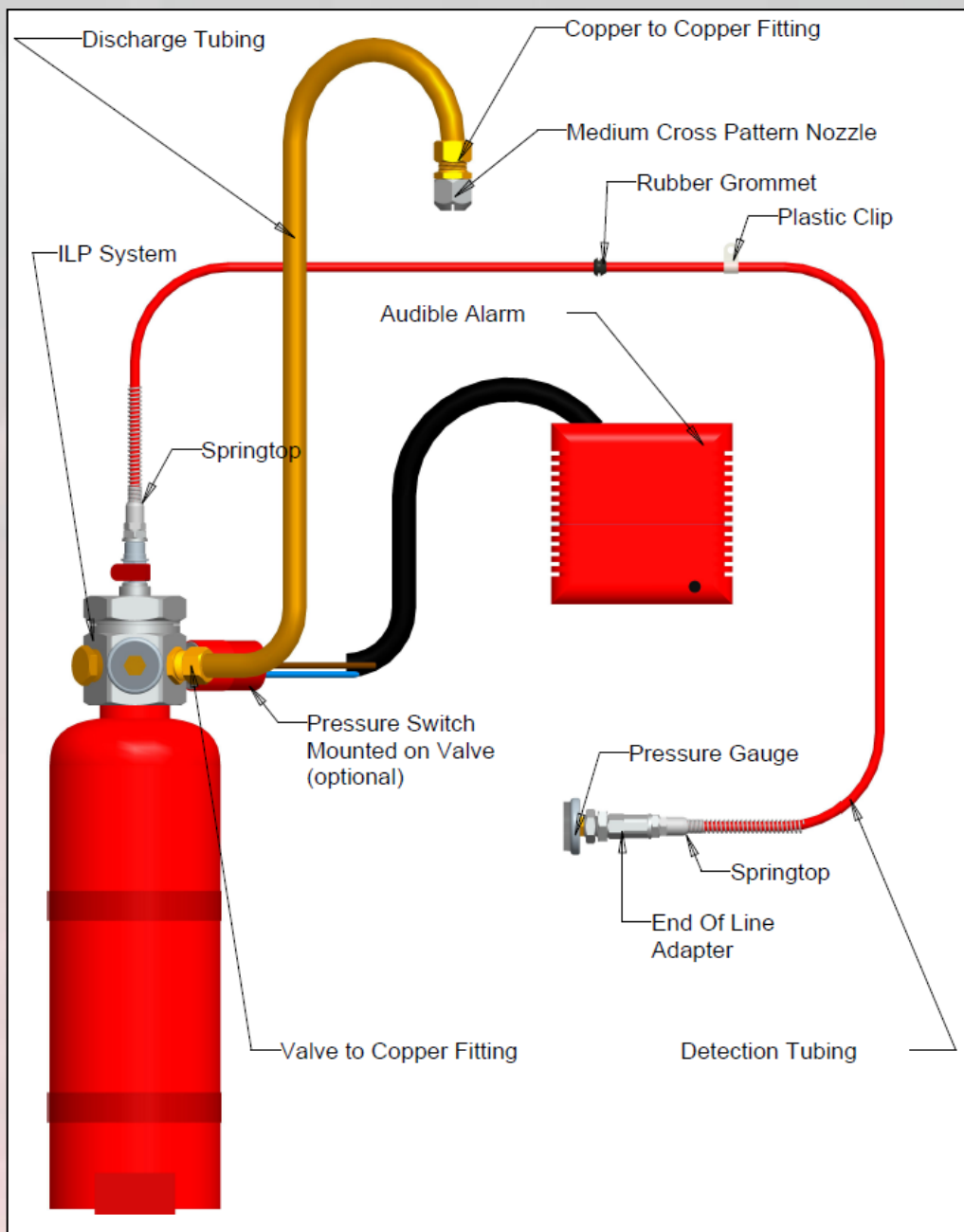

Valve Assembly

Each cylinder is equipped with a nickel plated brass valve, a pressure gauge to monitor cylinder pressure, and a quarter turn ball valve that interfaces with the Firetrace detector tubing. The ball valve must be kept closed at all times when the cylinder is not in service.

In addition, all DOT cylinder valves are equipped with a pressure relief (rupture disc) device in compliance with safety requirements

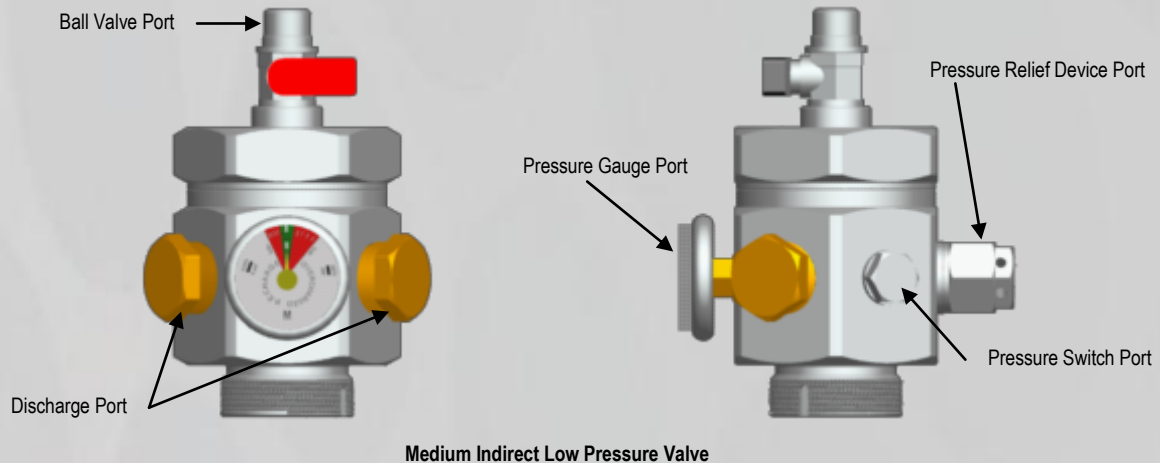

(CE Manufactured Systems for the European market do not require a pressure relief device)

Manual Release

All indirect systems come equipped with a manual release device which can be mounted in the front of the machine. This will allow the system to be activated manually in the event of an emergency



Pressure switch

A pressure switch is provided to monitor system pressure, system actuation and/or to energize or de-energize electrically operated equipment. This unit can be connected at the end of the line of the **FIRETRACE**[®] detector tubing, or on the container valve assembly to provide additional electrical functions as may be required. **FIRETRACE**[®] recommends that all systems use a pressure switch coupled with some device to alert personnel in the event of a system discharge.

System Choice for EDM machine

A typical EDM (Electrical Discharge Machining) machine can be protected using an indirect High pressure unit with carbon dioxide. The FDT can be installed directly onto the base of the ram, which is centred directly above the work. The ram will move up and down, but the base will remain stationary

In the event of a fire, or high temperature rise, the FDT will burst and activate the valve, now the agent is released through the discharge pipes and onto the fire. The agent will quickly cool and suffocate the fire all around the base as CO₂ is suitable for these open environments.

The system is also fitted with a pressure switch that constantly monitors the contents of the container and can be used to sound an alarm or be integrated into an existing fire alarm panel. It can also be used to shut powder down to the machine ensuring that the original fault (lack of lubricant etc...) will not cause the fire to re-ignite

Firetrace Detection Tubing is ideal for fire detection as it can be run as close to the arm as possible, this is where a fire is most likely to start and therefore is the best place to detect it.

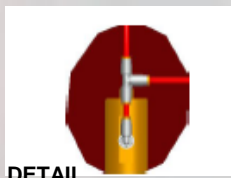
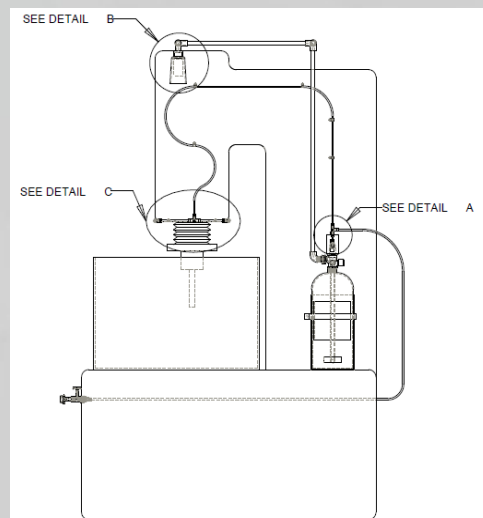
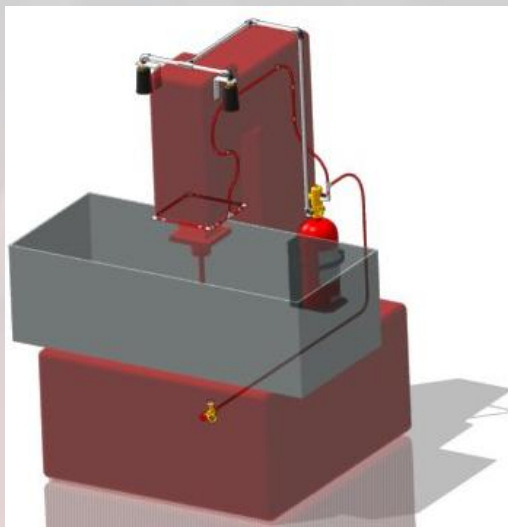

DETAIL



DETAIL

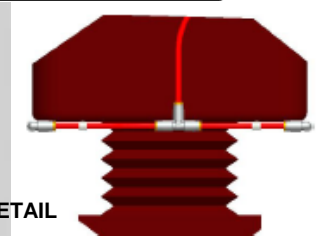

DETAIL

System Specifications

Cylinder and Mounting Bracket

FIRETRACE® systems can utilise both TPED and D.O.T high pressure cylinders made from either aluminium or steel. Each cylinder is finished in red and painted to resist corrosion.

A wall mounted painted steel bracket is used to mount the cylinder/valve assembly in a vertical (upright) position. Each bracket is equipped with integral quick-clamp straps and locking pin.

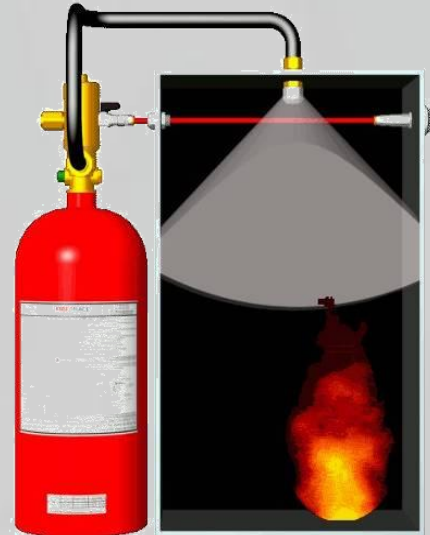

Indirect System Example

Valve Assembly

Each cylinder is equipped with a nickel plated brass valve for use with high pressure agents, and one 1/2" discharge port. A quarter turn ball valve interfaces with the Firetrace detector tubing to ensure the system is inactive during transport and maintenance.

In addition, all cylinder valves are equipped with a pressure relief (rupture disc) device in compliance with safety requirements

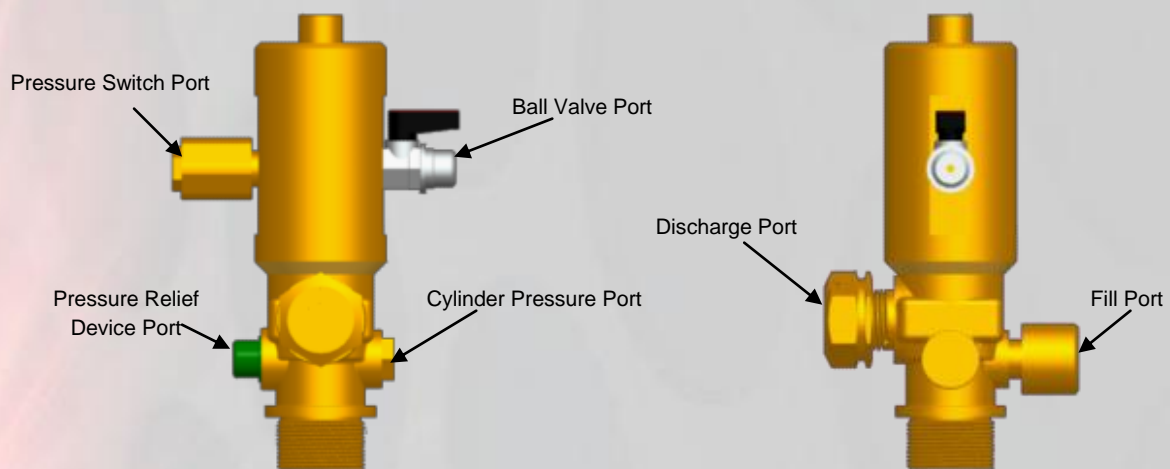

Indirect High Pressure Valve

System Choice for Dust and Mist Extractors



Typical dust and mist extractors can be protected using an indirect **FIRETRACE®** unit filled with an appropriate agent, whether it is oil mist or magnesium dust there is an agent to match. The FDT can be installed within the main housing and over all of the vents.

In the event of a fire, or high temperature rise, the FDT will burst and activate the valve, now the agent is released through the discharge pipes and onto the fire. Upon activation the integrated pressure switch can be used to shut down the extractor fan and prevent it from drawing flames up into the exhaust and into other areas.



System choice for control panels

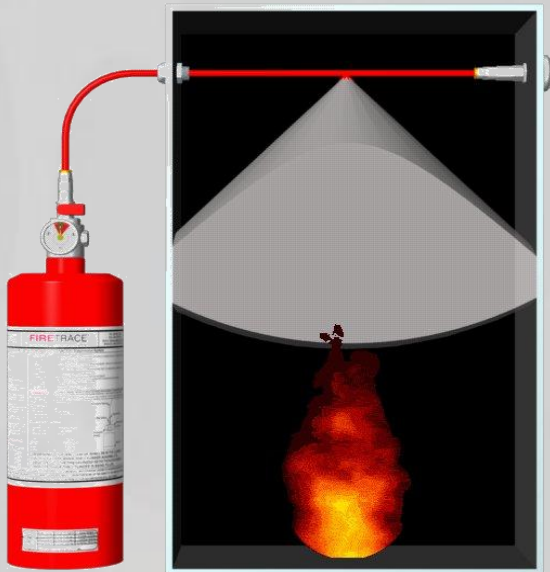

Direct System Example

A small fire in a control box can very quickly lead to a big fire if it goes un-noticed. It is difficult to predict electrical fires as they usually occur from simple loose connections arcing and igniting plastics around them. When they are located near to hot oil filled machinery this could lead to a devastating fire very quickly.

Electrical equipment such as Control cabinets and switchgear can be protected using our direct low pressure system filled with a clean agent such as Novec 1230 or HFC227ea. Using the same cylinder and detection tube the Direct **FIRETRACE**[®] system discharges the suppression agent directly from the burst hole in the tube, this will be the closest point to the fire, and will allow the fastest extinguishing time and minimum spread of the fire

As the fire is detected and extinguished within the panel, it is tackled while it is still a small fire. This means that there is minimal damage to the component in the panel and can reduce the downtime of the whole machine; you can also use one system to cover multiple cabinets or enclosures. Again this system can be integrated with a pressure switch to signal an alarm or shut down power.

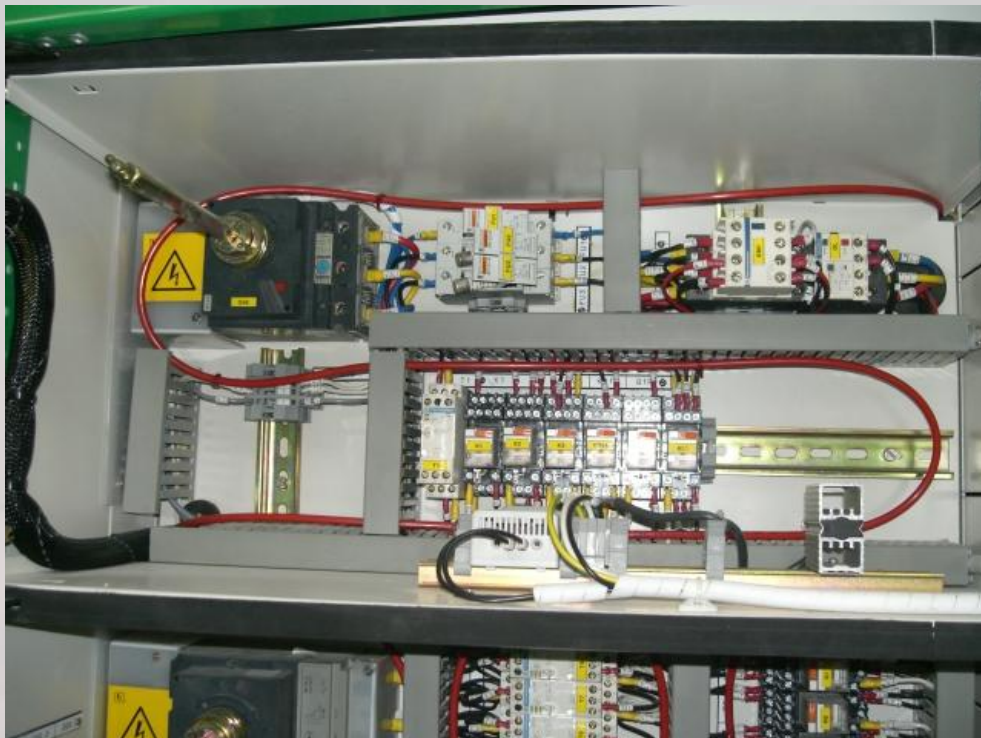

Firetrace system routed throughout the cabinet

FIRETRACE® Detection Tubing (FDT)

At the heart of all FIRETRACE® systems is the Firetrace Detection Tubing, or FDT. This flexible, pneumatic tubing is the primary fire detection and unit activation method used in all FIRETRACE® Automatic Suppression Systems. It is flexible enough to be used in the most difficult installations, yet durable enough to withstand harsh conditions and continue to perform as intended.



Firetrace Detection Tubing

The FDT is a linear, pneumatic, fire detection device that responds to a combination of heat and radiant energy generated by a fire. When exposed to these conditions, the properties of the FDT in this localized area change. The material becomes softer and weaker than the surrounding areas. In this weakened state, the gas contained inside of the FDT is able to burst through, releasing the pressure in the entire length of FDT. This rupture and depressurization of the FDT is what activates the rest of the system, which discharges the fire suppression agent.



FDT after Detection

The FM Approved Firetrace Detection Tubing (FDT) is a linear, pneumatic, fire detection device that responds to a combination of the heat and radiant energy from a fire. The FDT is non-porous, so it can contain internal pressure for an extended time. The FDT is also resilient to most common chemicals or substances. The FDT is made of an inert, non-conductive blend of proprietary resins, and then extruded using a special process to ensure that the tubing is non-porous. This unique blend of materials gives the FDT the following attributes:

- Excellent Physical Durability and Flexibility
- High Pressure Performance
- Wide Temperature Range
- Good Chemical Resistance*
- Excellent UV Resistance

*Tests on chemical resistivity performed by Oxford University

FIRETRACE® *Detection Tube Testing*

Leakage rate:

The FDT passed the Underwriters Laboratories and Factory Mutual Research long term leakage tests. Twelve sample systems, each with 52 feet of FDT were weighed and then placed in a secure storage area. The maximum allowable leakage rate was 0.0075 ounces leakage over a period of one year. Each quarter of a year, 4 random samples were selected and weighed. At the end of the full year, all twelve samples were weighed. There was no measurable leakage. The FDT passed the test.



Exposure to UV radiation:

Samples of FDT, each 12 inches in length, were subjected to the UV Light and Water Test in accordance with ASTM 154 utilizing the UVB 313 Lamp. Test duration was 1000 hours. Following this test, the samples were examined for cracking or deterioration. None was found. These same samples were then subjected to a hydrostatic test of six times the normal operating pressure ($150 \times 6 = 900$ psi) of the tubing for a period of one minute. There was no burst or leakage as a result of this test. Pressure was then raised to 1000 psi for a period of one minute with no burst. Each sample was then raised to burst pressure. Average burst pressure of the twelve samples was 1200 psi.

Aging Test:

A total of twelve samples of FDT, each twelve inches in length, were subjected to an air-oven aging test for 180 days at 212°F (100°C). Following this test, the samples were examined for cracking or deterioration. None was found. These same samples were then subjected to a hydrostatic test of six times the normal operating pressure ($150 \times 6 = 900$ psi) of the tubing for a period of one minute. There was no burst or leakage as a result of this test. Pressure was then raised to 1000 psi for a period of one minute with no burst. Each sample was then raised to burst pressure. Average burst pressure of the twelve samples was 1200 psi.

30 Day Extreme Temperature Leakage Test:

A total of twelve fully charged FIRETRACE® Indirect systems, charged with FM-200™ Clean Extinguishing Agent and super pressurized with nitrogen to 150 psi and including 24 inches of detection tubing (also charged to 150 psi) were exposed to the temperature extremes, 0°C (32°F) to 54.44°C (130°F), for a period of 30 days. A total of six charged systems were exposed to 0°F and six charged systems were exposed to 130°F. Weight (in grams) was recorded before and after the test. There was no loss of weight noted of any of the samples at the end of the test. Following this test the systems were discharged with a standard propane torch impinging on the FDT. System actuation was within two seconds and in each case, discharged as intended

Approvals & Listings



FIRETRACE® International's systems carry several internationally recognised approvals and listings and have been independently tested by third parties for exposure to many types of chemicals, solvents and UV radiation. As an **ISO 9001** accredited company you can be sure of the fact that all systems are manufactured and tested in a quality environment.

Australia – SSL Listing No. AFP 1368 Scientific Services Laboratory, Victoria, Australia

Austria – Prüfstelle für Brandschutztechnik

Bahrain – State of Bahrain Ministry of the Interior, Protection and Prevention Section

Belgium – ANPI/NVBB Rapport D'essai no. SPT/ME 020/1987.12.08

China – CNAACL No. China National Accreditation of Laboratories

Czech Rep – Strojirensky Zkusebni Ustav S.P Engineering Test Institute

Denmark – Danish Institute of Fire Technology

France – CNPP GC01 0017 CNPP IE 99 5585

Germany – BAM/TUEV Approval

Greece – Approval Report 44672 701.6

Hungary – Belügyminiszterium Tűezoltóság Országos Parancnokszag Szum 188/31/1999

Israel – The Standards Institution of Israel Test Certificate 8013107171

Italy – TESI No. 094/B Tecnologie Sviluppo Industriale

Netherlands – TNO Netherlands Project Ref 006.10329.01.02

Romania – SC Instal Somet SA Act de Omologare No. 7/2000

Qatar – Civil Defence

Sweden – SBF 128:1 Swedish Bus Approval

United States - Factory Mutual Approval / UL & ULC Listing

Frequently Asked Questions

What pressure is the system working to?

FIRETRACE[®] low pressure systems are super pressurized with Nitrogen to a pressure between 195psi (13.4bar) and 150psi (10.3bar).

What happens if I have more than one fire simultaneously?

Because the system design is based on the volume of the enclosure, there is sufficient agent within the container to “total flood” the whole space. Should there be more than one fire, the Fire Detection Tube will burst at the hottest point first and all of the agent will be dispersed. The whole

How can the operator check if the system is available and functioning?

A Firetrace system is fitted with two monitoring devices. A pressure gauge for visual inspection and also as described above the systems can be fitted with a set of low pressure switches which change state on 5bar falling pressure and can create “a fault” signal on a fire control panel. (Control panels are normally supplied by 3rd parties but Firetrace can supply these also).

If the system is activated, do I need to replace the whole system?

No. Should you have the unfortunate incident of a fire, the system will operate as intended and some works will obviously need to be carried out to bring the system back into operation again. This involves re-charging the contents of the container via an approved agent, or for speed purposes, replacing the container with an identical one that is already filled. The Fire Detection Tube will not normally need to be replaced, as the burst point can be cut from the tube and the tube can then be re-connected with a straight adapter. The system can then be pressurized and reset for use.

In theory, your system could be operational again within only a few minutes and at minimal cost.

How to contact us

FIRETRACE[®] International Ltd.

Unit 12, Fairlawn Business Park - Bonehurst Road, Salfords - REDHILL RH1 5GH

United Kingdom

Tel: +44 (0) 1293 780 390 - Fax: +44 (0) 1293 780 399

EMEA@firetrace.com - www.firetrace.com